

Lifting and tipping device type 27000



Lifting and tipping device type 27000

Ergonomic working

Application

The lifting and tipping device type 27000 offers particularly ergonomic and safe handling of 200 l and 300 l standard trolleys and special containers. It is an indispensable aid for charging machines and systems while ensuring high hygiene standards.

Version

- Device completely made of stainless steel, W.-no. 1.4301 with surface blasted by glass beads
- Lifting fork with safety device for a safe lifting and discharging
- The system is driven by a noncorrosive roller chain
- Hygienic lifting column with easily removable column cladding for maximum ease of maintenance
- The lifting and tipping device type 27000 is CE-compliant and approved by the BG

Options

- Adjustment for special containers possible
- Tilting device available for higher lifting loads
- Stationary or mobile design
- On request with table or conveyor belt connection
- Optionally available with integrated weighing

Technical data

Power supply	3x400V, further options
Power consumption	0.75 kW
Main frequency	50 Hz, further options
Tipping height	>5,000 mm
Tipping angle	>120°
Lifting weight	Max. 350 kg
Lifting speed	5 m/min.
Unloaded weight	From 300 kg netto
Protection class	IP65/54

Technical data may be subject to changes

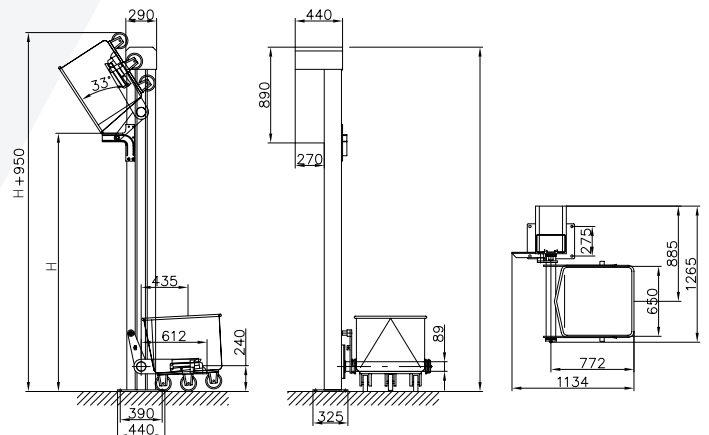

Contact

CN: shanghai@frontmatec.com
Phone: +86 215 859 4850

DK: kolding@frontmatec.com
Phone: +45 763 427 00

NL: rijssen@frontmatec.com
Phone: +31 886 294 000

UK: birmingham@frontmatec.com
Phone: +44 121 313 3564

frontmatec.com

DE: beckum@frontmatec.com
Phone: +49 252 185 070

ES: barcelona@frontmatec.com
Phone: +34 932 643 800

RU: moscow@frontmatec.com
Phone: +7 495 424 9559

US: kansascity@frontmatec.com
Phone: +1 816 891 2440