

Swing-Loader type 27100



Swing-Loader type 27100 with table



Swing-Loader type 27100

Ergonomic lifting and tipping

Application

The Swing-Loader type 27100 offers targeted ergonomic and safe handling of 200 l and 300 l standard trolleys or special charging trays. It is an indispensable aid for lifting and controlled emptying of containers while ensuring high hygiene standards.

Version

- Made entirely of stainless steel, material no. 1.4301
- Hygienic surface blasted by glass beads
- The drive of the system is electro-hydraulic and is done in controlled manner, i.e. a step-by-step discharging of the trays is possible
- Integrated hydraulic station and electric control
- CE-compliant and ready for connection

Options

- Special controls on request
- Stationary or mobile version
- Available with table and other attachments

Technical data

Power supply	3x400V, further options
Power consumption	1.5 kW
Main frequency	50 Hz, further options
Tipping height	Up to 1,700 mm
Tipping angle	120°
Lifting weight	Max. 350 kg
Lifting speed	0.2 m/s
Unloaded weight	From 200 kg net
Protection class	IP 65/54

Technical data may be subject to changes

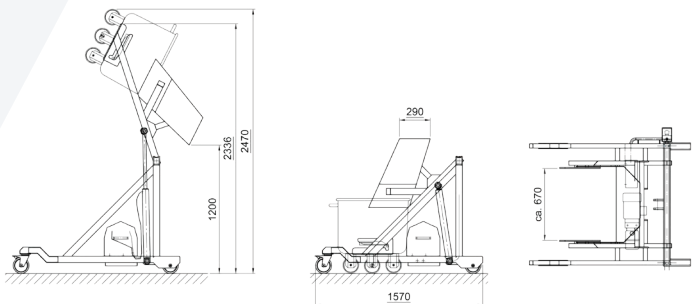

Contact

CN: shanghai@frontmatec.com
Phone: +86 215 859 4850

DK: kolding@frontmatec.com
Phone: +45 763 427 00

NL: rijssen@frontmatec.com
Phone: +31 886 294 000

UK: birmingham@frontmatec.com
Phone: +44 121 313 3564

frontmatec.com

DE: beckum@frontmatec.com
Phone: +49 252 185 070

ES: barcelona@frontmatec.com
Phone: +34 932 643 800

RU: moscow@frontmatec.com
Phone: +7 495 424 9559

US: kansascity@frontmatec.com
Phone: +1 816 891 2440